

and $\text{Pb}(\text{NO}_3)_2$, which are not volatile, do not produce signals.

Therefore, volatile vs. nonvolatile forms of Pb can be determined with this technique by determining volatile alkyllead compounds with the procedure given here and determining total lead by any of the other procedures described in the literature.

CONCLUSION

This paper has demonstrated that PbH_4 is not generated in organic media in conditions similar to those required in water. It has been proved that when lead is introduced in the form of a volatile organometallic compound, such as PbR_4 , the process that takes place is the volatilization of the PbR_4 itself and not the formation of PbH_4 as might be expected.

This volatilization is even more efficient, and therefore more economical, if instead of NaBH_4 , NaHCO_3 is used. The decomposition of the latter in situ in an acidic medium gives off CO_2 strongly and this, together with the carrier gas, carries the PbR_4 to the silica tube of the atomizer. A new, fast, sensitive, and accurate procedure for determining volatile lead compounds in gasoline is proposed, which has the additional advantage that it is direct and does not require prior handling or alteration of the sample; it is sufficient to dissolve it in Me_2SO .

A procedure for independently determining volatile lead compounds is proposed and opens up new methods for introducing volatile samples in AAS.

However, this method does not permit determination of the specific form of organometallic lead, but only the volatile lead

compounds. Moderately volatile lead organometallics have not been addressed in this paper and may present some analytical difficulties.

ACKNOWLEDGMENT

The authors wish to thank the Instituto Tecnológico de Aragón for the use of its facilities.

Registry No. PbEt_4 , 78-00-2; Pb, 7439-92-1; PbAc_4 , 546-67-8.

LITERATURE CITED

- (1) Messman, J. D.; Rains, T. C. *Anal. Chem.* **1981**, *53*, 1632.
- (2) De Jonghe, W. R. A.; Chakraborti, D.; Adams, F. C. *Anal. Chem.* **1980**, *52*, 1974.
- (3) D'Ulivo, A.; Fuoco, R.; Papoff, P. *Talanta* **1986**, *33*, 401.
- (4) Yamauchi, H.; Arai, F.; Yamamura, Y. *Ind. Health* **1981**, *19*, 115.
- (5) Aznárez, J.; Palacios, F.; Vidal, J. C.; Galbán, J. *Analyst (London)* **1984**, *109*, 713.
- (6) Nerín, C.; Cacho, J.; Urdániz, A., unpublished results, University of Zaragoza, 1985.
- (7) Kratochvíl, B. *Anal. Chem.* **1964**, *36*, 527.
- (8) Bonilla, M.; Rodríguez, L.; Cámara, C. *J. Anal. At. Spectrom.*, in press.
- (9) Aznárez, J.; Vidal, J. C.; Garnicer, R. *J. Anal. At. Spectrom.* **1987**, *2*, 55.
- (10) *Annual Book of ASTM Standards*; American Society for Testing and Materials: Philadelphia, PA, 1983; Vol. 05.03, Petroleum Products and Lubricants Method D 3341-80.
- (11) *Annual Book of ASTM Standards*; American Society for Testing and Materials: Philadelphia, PA, 1983; Vol. 05.03, Petroleum Products and Lubricants Methods D 3116-82.

RECEIVED for review December 10, 1986. Accepted April 2, 1987. This work was carried out as part of Project ITE/85 of the Diputación General de Aragón.

Detection of Capsule Tampering by Near-Infrared Reflectance Analysis

Robert A. Lodder, Mark Selby,¹ and Gary M. Hieftje*

Department of Chemistry, Indiana University, Bloomington, Indiana 47405-4001

The growing incidence of product tampering has brought to attention the need for a rapid, reliable, inexpensive, noninvasive, and nondestructive method of screening. Such a method, based on near-infrared reflectance analysis (NIRA), is presented here for the detection of adulterated nonprescription drugs. The method relies upon a nonparametric clustering algorithm known as the BEAST (bootstrap error-adjusted single-sample technique). Specially designed sampling reflectors have been constructed to enable rapid and convenient measurement of capsules. A right-circular conical reflector has been found to be optimal for this purpose; the capsules fit directly into the reflector and need not be opened for analysis. A variety of foreign substances have been successfully detected in capsules by probing the capsule contents directly through the gelatin walls; these substances include Fe_2O_3 , Al shavings, NaF, As_2O_3 , NaCN, and KCN. The NIRA response for KCN is linear down to a detection limit of 2.6 mg (0.4% of capsule weight). An incidental advantage in the use of the conical reflector is that the response is dependent upon not only the mass of adulterant but its location within the capsule. The ability to noninvasively determine the location of foreign substances within capsules might be important in forensic applications of the method.

¹ Present address: Varian Techtron Pty. Ltd., P.O. Box 222, Springvale, Victoria, Australia 3171.

The well-publicized adulteration of nonprescription capsules with poisons has called attention to the need for rapid, noninvasive, and nondestructive methods of screening over-the-counter drugs. In 1982 potassium cyanide appeared in capsules of Extra Strength Tylenol in the Chicago area and resulted in seven deaths (1, 2). Subsequently, a number of "copycat" incidents occurred, involving such things as strychnine, mercuric chloride, and sodium hydroxide in capsules, hydrochloric acid in eyedrops, and sodium fluoride in an artificial sweetener (2-4). Concern about drug tampering has continued to grow; earlier this year cyanide-laced Tylenol capsules caused the death of a woman in the New York area (5, 6), and even more recently Excedrin capsules containing cyanide resulted in two further fatalities in the Seattle area (7).

The number of cases of product tampering appears to be increasing. In addition to analgesics, other types of capsules, including cold and allergy remedies and an appetite suppressant, have been affected (8, 9). The cost to Johnson and Johnson alone, the maker of Tylenol, is estimated to be \$150 million (10) for the most recent recall of capsules. Litigation concerning the 1982 Tylenol poisoning is still proceeding; however, there is an indication that judges and juries alike are beginning to hold manufacturers responsible for tampering, even when there is no evidence linking the company to the actual incident (under the doctrine of *res ipsi loquitur*, i.e., the thing speaks for itself) (11). In such cases the burden falls

upon the company to prove that tampering did not occur in the company's plant (11). It is the objective of this report to demonstrate that near-infrared reflectance analysis (NIRA), combined with a suitable cluster-analysis algorithm, can be used to indicate that capsules (or similar products) have or have not been adulterated.

Subsequent to the 1982 incident the Food and Drug Administration (FDA) collected and tested 2 million capsules of Tylenol in a search for contaminated bottles of the drug (12). Capsules were batched into groups of 5–10 for analysis. While the FDA avoided much publicizing of its methods, several techniques have been reported for various capsule analyses, including such simple methods as inspection by visual appearance and odor. In the Tylenol case the capsules had been grossly contaminated with 500 to 800 mg of KCN, and the KCN consisted of fairly large crystals while the analgesic was a powder of small particle size (4, 12). Potassium cyanide is also deliquescent, which resulted in a readily identifiable distortion and discoloration of some of the adulterated capsules. KCN can also emit an odor of bitter almonds (13, 14). Nevertheless, the possibility exists that tainted capsules will not be spotted and, in any case, the procedure is not suitable for detecting lower-level contamination. In another case, UV spectrometry has been used to identify substitution of phentermine, (phenylpropanol)amine, and caffeine (15). Thin-layer chromatography (15) and microcrystal tests have also been used to detect counterfeit Ionamin capsules (15). X-ray spectrometry, using grain inspection or clinical mammographic instrumentation, has been employed to detect cyanide in Tylenol capsules (12); however, the majority of these determinations were performed by using differential pulse polarography of cyanide reduction at about -0.3 V vs. SCE (12). Inductively coupled plasma atomic emission spectrometry (ICP-AES) of trace elements in KCN has also been used to obtain an elemental "fingerprint" of the tainted capsules in an effort to trace the source of the KCN (4). With the possible exception of X-ray methods, all of the above techniques require that the capsules be opened and their contents emptied for analysis. Clearly, a nondestructive method of probing the contents of suspect capsules (or similar products) directly through the walls of the container would be desirable for rapid screening in large numbers. NIRA, in conjunction with appropriate data analysis, is suitable for such a screening of over-the-counter drugs and is simpler and less expensive to implement than X-ray methods.

NIRA is a rapid analytical technique that typically uses the diffuse reflectance of a sample at several wavelengths to determine the sample's composition (16). Through a computerized modeling process NIRA is able to correct automatically for background and sample-matrix interferences, making ordinarily difficult determinations seem routine. This modeling process employs a "training set" of samples to, in effect, "teach" the computer to recognize relationships between minute spectral features and sample composition. Of course, the contents of the training-set samples must have been previously determined by some other method.

The model developed in NIRA is composed of linear equations of the form

$$[A] = C_0 + \sum_{i=1}^n C_i R_i \quad (1)$$

where A is the sample component of interest (one equation is required for each component), n is the number of wavelengths, R_i is the reflectance at the i th wavelength, and the C 's represent the constant factors determined through a multiple regression process. In other words, the model gives the sample composition from a number of linear equations, each of which expresses a particular component concentration

as a weighted sum of the reflectances observed at a number of wavelengths.

The instrument used in NIRA can be as simple as a filter photometer or as complex as an FTIR (the former is more common than the latter). The broad spectral features and highly correlated wavelength vectors (R_i 's) make only a few filters (less than 10) usually necessary, so NIRA instruments are relatively inexpensive. Little or no sample preparation is required in NIRA, and powders can be directly analyzed. Finally, near-infrared radiation penetrates most compounds rather well because the absorptions in this spectral region are usually weak. These basic characteristics suggest that NIRA can be easily and profitably employed in the detection of tampering.

However there is an obstacle to such a use of NIRA: it is not possible to predict what might be placed in a particular product. The modeling process described above relies on the availability of a training set composed of known products and known contaminants. Even if one could assemble sets of all of the products and adulterants that have been involved to date, there is no guarantee that a new adulterant would not appear in the product tomorrow. Unfortunately, when a multiple regression model is used, any amount of reflectance at the selected analytical wavelengths generates some sort of composition value regardless of the material responsible for the reflection. In other words, when a sample contains a component that is not present in the training set, erroneous composition values can result without any indication of the error.

One cure for this problem would be to find a method of spotting anomalous samples based on their near-infrared spectra. The use of such a method would allow different linear models (calibration equations) to be applied in the analysis of the components of different samples. The problem of assigning a particular spectrum to a particular linear model has been called the "false-sample problem", and a method has been proposed to solve it (17). This method, the Quantile BEAST (bootstrap error-adjusted single-sample technique), goes beyond a simple qualitative analysis of mixtures to determine whether a quantitative prediction equation applies to a particular sample. This method can be used to (1) detect any tampered product by determining that it is not similar to the previously analyzed unadulterated product, (2) qualitatively identify the contaminant from a library of known adulterants in that product, and (3) provide a quantitative indication of the amount of contaminant present.

THEORY

The Quantile BEAST considers each monitored wavelength to be a dimension in hyperspace. For example, a spectrum recorded at n wavelengths can be represented as a single point in n -dimensional hyperspace, translated from the origin in each dimension by an amount that corresponds to the magnitude of the reflectance observed at each wavelength. In this scheme, similar spectra appear in similar regions of hyperspace. The distribution of reflectances on each wavelength axis provides a projection of the clusters of similar points (spectra) (see Figure 1). Valid (unadulterated) samples are defined as those that fall inside the cluster of training-set points when the BEAST is trained with unadulterated product samples. False (tampered) samples are those that fall outside of the same cluster. Confidence limits are set along any linear combination of wavelengths (dimensions) to define the surface of the cluster at a specified level.

These confidence limits are obtained by using a bootstrap procedure (18) to arrive at an estimate of the real-sample distribution based on the training-set distribution. The bootstrap procedure has three basic steps:

- (1) A training set is carefully constructed from real (in this

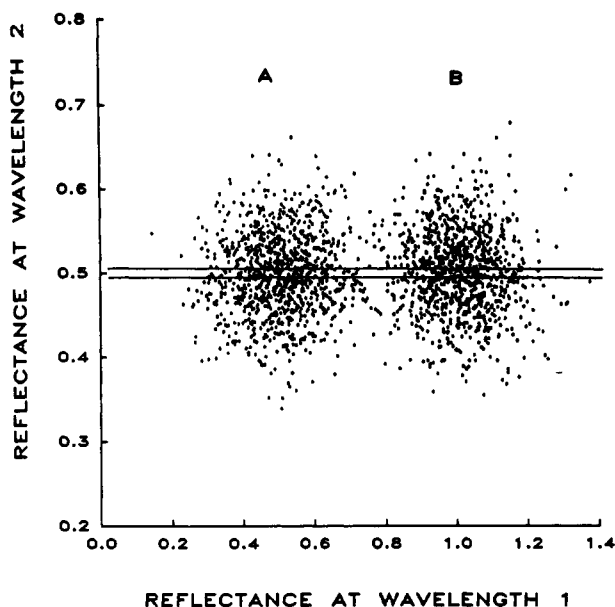

Figure 1. Two hypothetical compounds, A and B, whose spectra are measured at two wavelengths. Uncertainty in the measurements at each wavelength is represented by taking 1000 replicate spectra of both A and B, resulting in clusters of points varying about A and B. The centers of the clusters represent the best point estimate of the spectra of A and B. A line is defined by the centers of the two clusters, and the locus of all points within a user-specified distance of this line forms a cylinder in the space or three or more dimensions.

case unadulterated) samples in a way that captures all of the possible sample variance. Fortunately, NIRA is predicated on the construction of such training sets, and a good deal of knowledge has been accumulated in this area (19, 20). Spectra are then recorded to produce training-set points in hyperspace.

(2) A randomly selected set of samples (the same size as the training set) is chosen from the training set, with replacement from the training set, to form a bootstrap sample set. The bootstrap sample set is analyzed as though it were an actual sample set—in the tampering work, this analysis is based on locating the center of the sample distribution in hyperspace.

(3) The complete hyperspace distribution of real-sample centers is approximated by the bootstrap distribution of centers. This approximation is calculated by using a Monte Carlo integration of the bootstrap distribution while the training set is held fixed at the values obtained in step 1. After it develops an estimate of the real-sample distribution from the training set, the BEAST computes the center of the real-sample distribution. When a new sample (suspect product) is analyzed, its spectrum is projected as a point into this hyperspace. A vector is then formed in hyperspace between this new spectral point and the computed center point of the real-sample distribution. A hypercylinder formed around this line (with a radius typically 2 or 3 orders of magnitude smaller than its length (17)) will contain a number of BEAST-estimated real-sample spectral points. When the coordinates of these points are transformed into distances from the estimated center of the real-sample distribution, a univariate distribution is formed. It is this univariate distribution that is used to construct confidence limits by selecting two quantiles in one of the clusters (17). The reliance of the BEAST on nonparametric techniques (techniques that assume no particular underlying distribution) produces an analytical method that functions without assumptions about the shape, size, symmetry, or orientation of spectral-point clusters in hyperspace. This freedom is important because cluster characteristics have been shown to be unpredictable (17). The detection of abnormal capsules encompasses both process-

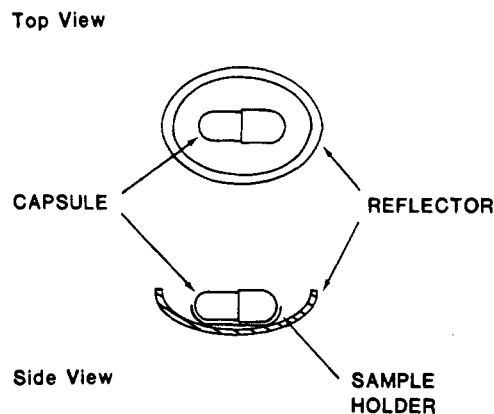

Figure 2. Elliptical reflector used in the initial capsule-tampering experiments. The reflector fits into the open sample cup supplied with the InfraAlyzer 400. The sample cup is then positioned in the sample drawer in the usual fashion for analysis.

control applications (in which empty capsules, rust, metal shavings, etc. are of interest) and the identification of instances of deliberate tampering (in which almost anything might appear in the capsule). Under such widely varying conditions the unpredictability of the cluster characteristics can only be magnified, making the use of nonparametric techniques even more worthwhile.

EXPERIMENTAL SECTION

Equipment Used. Spectral data for all of the experiments were collected at 18 discrete wavelengths by a Technicon InfraAlyzer 400 filter spectrophotometer connected to a VAX 11/780 computer (Digital Equipment Corp.) and with custom interface, graphics, and database-management programs. These programs, and the BEAST algorithm described earlier, were written in Speakeasy IV Delta (VMS version, Speakeasy Computing Corp., Chicago, IL) and VAX 11 Basic (Version 2.4). The programs can be obtained by arrangement with the authors at the address given above.

Reproducible positioning of capsules is important in minimizing the error of repeated readings of the individual capsules. The initial results (with Hook's Cold Caps [cold remedy capsules]) were obtained by placing the capsules into an elliptically shaped aluminum reflector (no. 1468 Progressus Co., Freeport, NY) (see Figure 2). Reproducible positioning of the capsules within the reflector was achieved by removing the "blister" from a Cold Caps "blister-pack," trimming it to about 2 mm in height, and gluing it into the center of the reflector with the open side up.

Datril and Anacin-3 capsule results were obtained by using a 90° conical reflector machined from aluminum (Figure 3). A nichrome wire support was used to achieve reproducible upright vertical capsule positioning within the cone. Optical surfaces of both reflectors were polished with a commercial polishing paste.

Materials Used. Three brands of capsules were selected for this study: (1) Hook's Cold Caps (Hook's Drugs, Inc., Indianapolis, IN), an allergy and cold remedy containing a decongestant (phenylpropanolamine hydrochloride) and an antihistamine (chlorpheniramine maleate), colored red and white; (2) Extra Strength Datril capsules (500 mg acetaminophen [N-(4-hydroxyphenyl)acetamide], Bristol-Myers Co., New York), colored green and white; (3) Maximum Strength Anacin-3 capsules (500 mg acetaminophen, Whitehall Laboratories, Inc., New York), colored blue and white.

The adulterants selected for study can be divided into two categories: those that might appear in capsules as the result of process-control problems and substances that are more likely to appear as the result of deliberate tampering. The process-control substances tested were (1) ferric oxide, reagent grade (J. T. Baker Chemical Co., Phillipsburg, NJ) and (2) aluminum metal, 20 mesh (Fisher Scientific, Fairlawn, NJ). The substances selected that are more likely to be present as the result of deliberate tampering were as follows: (1) arsenic trioxide, reagent grade (Fisher Scientific), lowest lethal dose reported for humans 2.941 mg/kg (or 206 mg for an average 70-kg person) (13); (2) sodium fluoride,

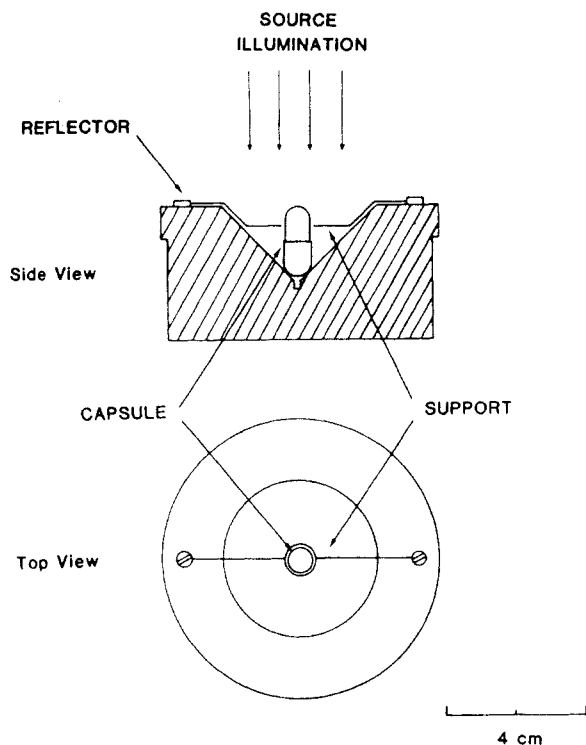

Figure 3. The 90° right-circular conical reflector used for most of the capsule-tampering experiments. This reflector replaces the cups provided for use with the spectrophotometer and fits directly into the sample drawer. The conical reflector design permits some spatial profiling of the contents of the capsule.

reagent grade (MCB, Norwood, OH), lowest lethal dose (oral) reported for humans 75 mg/kg (or 5.25 g for a 70-kg person) (13); (3) crystalline sodium cyanide, reagent grade (Aldrich Chemical Co., Milwaukee, WI), lowest reported lethal (oral) dose for humans 2.857 mg/kg (or 200 mg for a 70-kg person) (13); (4) granular potassium cyanide, reagent grade (Mallinckrodt, Paris, KY), lowest lethal dose reported in humans 2.941 mg/kg (or 306 mg for a 70-kg person) (13). All adulterants were added to the capsules on an "as is" basis without any grinding, sifting, or sample preparation. One or two grams of the cyanide was removed from the reagent container at a time and kept covered to reduce the absorption of water. Capsules were filled from this covered reservoir and no additional steps were taken to control water absorption.

Each experiment performed with the capsules began by training the BEAST (with 10–13 unadulterated capsules) to recognize a "good" capsule. The training process was then tested by using the BEAST to measure the distance (in standard deviations) of the same number (10–13, depending upon the capsule brand) of "good" capsules from the center (mean) of the training-sample cluster. The surface of a cluster was defined as being 3 standard deviations (SDs) away from its center (mean). In theory, then, all of the "good" test capsules (validation capsules) should appear less than 3 SDs from the training-set center, while all of the "bad" capsules (contaminated samples) should appear more than 3 SDs from the training-set center.

Types of Experiments Performed. The first experiment involved placing arsenic trioxide, sodium fluoride, sodium cyanide, ferric oxide, and aluminum shavings in cold capsules to test the feasibility of using NIRA to analyze the contents of intact capsules. Two wavelengths were monitored while using the simple elliptical reflector. On the basis of this experiment, the second conical reflector was designed and tested with Datriil capsules. Further experiments employed the conical reflector to analyze intact Datriil and Anacin-3 capsules at four wavelengths. The spatial response and orientation effects of sodium cyanide in Datriil and Anacin-3 were determined, and a detection limit was calculated for potassium cyanide in Anacin-3.

Analysis of the Sample Reflectors. The empty elliptical reflector (Figure 2) gave $\log(1/R)$ values at 18 wavelengths between 0.31 and 0.42. When a capsule was placed in the reflector, these values roughly doubled. It was thought that the amount

of specular reflectance passing from the reflector to the detector and bypassing the sample capsule must be rather large. A new reflector (Figure 3) was constructed to reduce the specular reflectance. This 90° conical reflector, when empty, reflects radiation back toward its source, parallel to the incident beam. When a sample capsule is positioned along the axis of rotation of the conical reflector, the specular reflectance can be minimized while the diffuse reflectance is maximized. Radiation reflected from the surface of the capsule is returned to the source when the incident radiation is perpendicular to the base of the cone (this is the configuration used in the spectrophotometer). Radiation is then focused along the length of the capsule. Any radiation that might pass through the capsules without being scattered is also returned to the source. The bulk of the radiation reaching the detector is therefore radiation scattered by the contents of the capsule.

If one assumes that the base of the conical reflector is uniformly illuminated by collimated radiation (this is the way that the spectrophotometer is designed), the amount of radiation incident on any given section of the capsule is directly proportional to the curved surface area of the frustum in which it lies. In turn, a frustum (a conic section taken parallel to the base of the cone) near the vertex and a frustum near the base of the same cone do not have the same curved surface area. (The curved surface area of a frustum is given by $\pi s(r_1 + r_2)$, where r_1 and r_2 are the radii of the base and top of a right circular frustum, respectively, and s is the length of the generator line, i.e., the length between the top and bottom measured along the surface of the cone).

Suppose that the length of the capsule is divided into 1-mm sections and that these slices are numbered from 1 to 20, starting at the end of the capsule toward the vertex of the cone. From the discussion in the preceding two paragraphs, the top slice of the capsule (i.e., slice no. 20) receives 39 times more light than the bottom slice (slice no. 1). In fact, the amount of light (P) received by a particular slice numbered R (the height of the section above the inverted vertex of the cone) is given by

$$P = k(2\pi 2^{1/2})R - \pi 2^{1/2} \quad (2)$$

Of course, there is not a detector on each 1-mm section of the capsule. Instead, there is a detector inside an integrating sphere, and the signal from the entire capsule is integrated to produce the detector response:

$$\text{detector response} = k(\pi 2^{1/2})R^2 - (\pi 2^{1/2})R' \quad (3)$$

where k and k' are proportionality constants that depend principally on the amount of incident radiation and the nature of the material in the capsule and R' is the total number of vertical capsule "slices" filled, i.e., from $R = 1$ to R' .

The diameter of the incident beam in our instrument is 26 mm, making direct illumination of the upper segments ($R = 13$ to 20) by the incident beam the predominant factor in producing a signal from this region. The amount of light on each slice decreases exponentially as the slice number is decreased in this zone. Of course, the entire cone is filled with scattered light, and the thickness and composition of the capsule wall are not uniform over the capsule length. These two factors, combined with the probable sample inhomogeneity, prevent a simple analysis from completely explaining the signal observed from an individual capsule. However, the overall response follows the trends outlined above.

Computation Procedure. A training set composed of 10 capsules produces a total of 92 378 possible bootstrap samples (calculated from $2n - 1$ combinations of n points, taken n at a time with replacement from the training set). Calculation of 1000 bootstrap replications represents more than 1% of the possible bootstrap distribution, a greater proportion of the distribution than is usually covered by Monte Carlo techniques. A compromise between coverage and execution time must be reached when one uses the BEAST; therefore, 1000 bootstrap replications were used for all the foregoing capsule experiments, resulting in a BEAST analysis time of about 4 s/capsule. A BEAST algorithm optimized for process control instead of research would be even faster. A training-set size of only 10 capsules is rather small, yet is large enough for the capsule experiments because the variability is small from capsule to capsule among the uncontaminated samples. In

Table I. False-Sample Sets for Hook's Cold Cap Capsules Adulterated with Various Substances

adulterant	distances from unadulterated capsule training-set cluster for test capsules, SD				
	cap 1	cap 2	cap 3	cap 4	cap 5
NaF (100%)	10.26	10.07	10.23	10.22	9.63
As ₂ O ₃ (100%)	10.16	10.26	10.33	10.24	10.22
Al (100%)	6.96	7.24			
Al (20%) ^a	3.58	4.90			
Fe ₂ O ₃ (100%)	8.47	8.56			
Fe ₂ O ₃ (30%) ^a	6.65	7.47	7.12		
NaCN (100%)	10.57				
empty cap	11.09				

^a The remainder of the capsule was filled with the ordinary capsule contents, i.e., cold remedy.

general, as the variability of the mixtures in the training set increases, the number of training samples required by the BEAST also increases. This requirement is a common one among NIRA techniques and is ordinarily not too burdensome. In order to assure that there were enough points (about 50 are required) in the hypercylinder to set confidence limits, the hypercylinder radius was set at 0.00060 (17). This value has the same dimensions as the log (1/R) values collected by the spectrophotometer. The reproducibility of BEAST distances is a function of the number of bootstrap replications employed, the hypercylinder radius, and the training set. The parameters given above (and used to obtain all of the experimental results) have been found to give RSDs around 7% (17).

RESULTS AND DISCUSSION

Table I and Table II summarize the results of the cold-capsule and analgesic experiments. Ten Hook's Cold Caps were used to train the BEAST at two wavelengths; it was assured that extreme cases of the standard capsules were adequately represented in the training set on the basis of the most unusual spectra. The net effect of this procedure is to make the training-set cluster in hyperspace larger and the distances measured in this space in SDs smaller. Although this procedure increases the likelihood that unadulterated capsules will test as "good" it also makes it more likely that adulterated samples will test similarly. However, this error would arise only when contaminated samples are spectroscopically very similar to the uncontaminated ones; such similarity was not observed in any of these experiments. The most likely effect of exaggerating the training set with extreme examples of unadulterated capsules is the raising of the detection limit for some contaminants. The importance of this

possibility will be examined below.

The distances of the spectra of 10 unadulterated cold capsules, in units of standard deviations, from the center of the hyperspace cluster of training-sample spectra are as follows: 0.30, 0.69, 0.42, 0.38, 0.85, 0.70, 0.33, 0.58, 0.23, 0.84. These 10 capsules are not the 10 that were used to train the BEAST and serve therefore to validate the results of the training process. The fact that all of these distances are less than 1 SD indicates that the BEAST is unlikely to reject a good capsule accidentally. Table I gives the distances of the spectra of 21 contaminated cold capsules from the center of the training-set spectral cluster. In every case the distance exceeds the 3 SD limit set as the dividing line between "good" and "bad" capsules. The results indicate that a variety of contaminants can be detected in intact capsules by using only two NIR wavelengths and a simple reflector-based capsule mount. Aluminum shavings are clearly detectable inside the capsule even though the reflector is also aluminum. A completely empty capsule can be easily differentiated from a capsule contaminated with aluminum. The BEAST algorithm works by detecting the absence of components that should be present as well as by detecting the presence of components that should be absent. This type of functioning gives the BEAST a powerful ability to detect all kinds of tampering. Presumably, it is the absence of cold remedy, combined with the added scattering of specular radiation from the aluminum shavings inside the capsule, that produces the differences between the aluminum-containing capsules and the cold remedy that are measured by the BEAST.

Spatial Characteristics of the Capsules. When an adulterant is packed into a capsule and the capsule spectrum is measured in the conical reflector, the results can be fairly well predicted by our model of the detector response. Figure 4 shows the actual response (in SDs from the center of Datriil training set) of four Datriil capsules containing 93, 218, 289, and 383 mg of sodium cyanide. This cyanide was packed into the white end of the capsule, which was oriented toward the vertex (bottom) of the conical reflector. The slight differences between the theoretical and observed results can probably be attributed principally to two factors: (1) the thickness and opacity of the capsule itself are not constant from one end to the other (for instance, there are two layers of gelatin in the middle of the capsule); (2) peculiarities are introduced into the capsule spectra, and therefore into the distances in SDs, by the particular orientations that the capsule contents (both sodium cyanide and acetaminophen crystals) assume in a single capsule packing.

Table II. Distances of Spectra of Sodium Cyanide Containing Capsules from the Training-Set Spectral Cluster (in SD)

NaCN (mg)	Datriil ^a			Anacin-3 ^b			
	green end ^c	white end ^c	mixed in	NaCN (mg)	blue end ^c	white end ^c	mixed in
4 Wavelengths, 4-D space							
100	26.89	3.69	6.76	100	11.57	2.30	1.52
200	29.37	9.18	3.95	200	7.51	8.15	3.27
300	32.17	18.16	7.18	300	9.86	15.50	5.09
400	34.82	26.02	16.23	400	16.99	18.03	11.26
							30.91 ^d
							32.70 ^d
4 Wavelengths + Weights, 5-D Space							
				100	7.49	3.77	4.62
				200	5.64	5.61	4.45
				300	7.40	10.70	3.75
				400	14.27	11.99	7.33
							25.92 ^d
							31.61 ^d

^a Mean total mass of capsule = 694 mg. ^b Mean total mass of capsule = 670 mg. ^c End of capsule into which adulterant was added. ^d Pure NaCN.

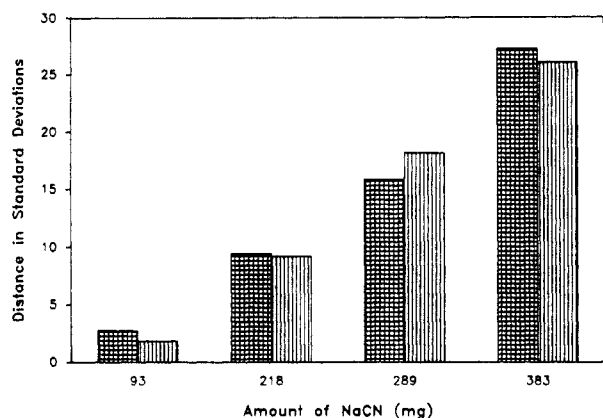

Figure 4. The theoretical and actual response for a contaminant packed in the lower end of a Datriil capsule in the conical reflector. The first bar (crosshatch) represents the scaled NaCN theoretical distance (from eq 3) response of the BEAST for an adulterated capsule filled from the bottom to the top in 100-mg steps. The second bar (vertical lines) represents the actual response of the BEAST for NaCN packed into the white (bottom) end of a Datriil capsule.

Knowledge of the characteristics of the conical reflector permits some spatial profiling of the capsule for a given contaminant. A specific BEAST response can indicate either a relatively large amount of contaminant in the lower sections of the capsule or a relatively small amount of contaminant in the higher sections. This classic dilemma—that of too many unknowns and too few equations—is solved simply by inverting the capsule and running the BEAST again. The total amount of contaminant in the capsule is obtained by developing ordinary NIRA calibrations from homogeneous training sets (containing only one type of capsule configuration).

Discriminating Ability of the Reflectors. The most important feature of the reflector cone, however, is its ability to discriminate between capsules with similar component concentrations. This ability is demonstrated by an experiment conducted with four tainted Datriil capsules. Capsules 1 and 2 contained about 170 mg of NaCN, while capsules 3 and 4 contained about 460 mg of NaCN. The remainder of each capsule was composed of the acetaminophen powder normally found in the capsules, giving an average total capsule mass of about 600 mg. Data were collected at four wavelengths with both the elliptical and conical reflectors, and the Euclidean distances among the spectra of the four capsules was determined.

The reflector with the greatest discriminating capability maximizes the average distance ratio

$$\frac{\text{distance between spectra of dissimilar capsules}}{\text{distance between spectra of similar capsules}}$$

This ratio was calculated for each reflector by using all possible combinations of the four capsules. The average ratio was only 3.83 when using the elliptical reflector but climbed to 10.53 for the same capsules when using the cone. These results indicate that the conical reflector is more sensitive to slight differences in capsule composition, probably because less specular reflectance (from the reflector and the surface of the capsule) reaches the detector with this corner-reflector configuration.

Spectroscopically, the ends of most capsules are not equivalent. In Anacin-3 and Datriil, the shorter end of the gelatin capsule is brightly colored (blue in Anacin-3 and green in Datriil) while the longer end is white and contains a light-scattering medium. Figure 5 shows the training, validation, and NaCN-containing sample sets for Anacin-3 in a two-wavelength space. The two distinct training clusters and the two distinct validation clusters are the result of including both of the possible orientations of Anacin-3 in the reflector

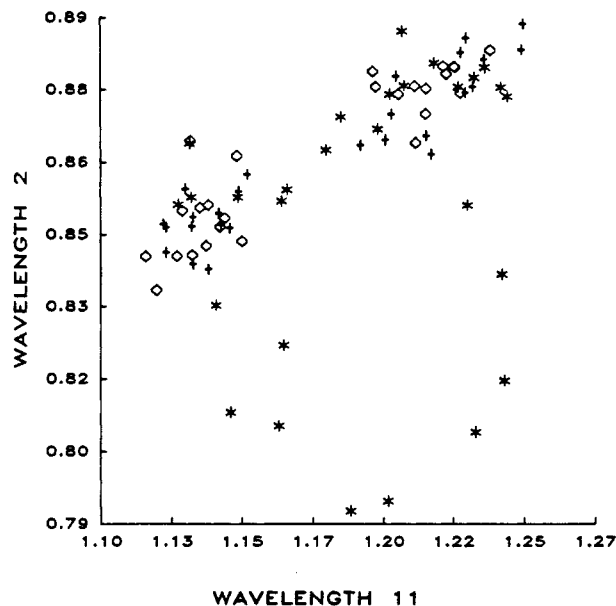

Figure 5. Spectral clusters of Anacin-3 capsules obtained at two wavelengths with the conical reflector and with both orientations (colored end up and colored end down). The cluster on the left is formed by readings taken with the colored end up in the cone, while the cluster on the right is formed from the same capsules, read with the colored end down in the reflector. The symbols represent training-set capsules (\diamond), validation-set capsules (+), and cyanide-containing capsules (*).

cone (colored end up and colored end down) in the plot. It is interesting to note that the corresponding training and validation clusters are not necessarily the same size or shape, even though the same capsules were used in each and only the capsule orientation in the cone had changed. In addition, the major axes of the NaCN-containing clusters are approximately perpendicular to those of the training and validation samples. These facts demonstrate that the size, shape, and directional orientation of spectral clusters in space are not predictable a priori. This unpredictability, in turn, violates basic assumptions of other qualitative NIRA techniques (21, 22), making their use in many applications somewhat suspect.

Datriil capsules containing approximately 100, 200, 300, and 400 mg of NaCN in three configurations (NaCN packed in the colored end of the capsule, in the white end, and mixed into the acetaminophen throughout the capsule) were analyzed at four wavelengths by means of the conical reflector. It was desired to determine the BEAST distance response (in SDs) for different amounts of contaminant in various locations throughout a capsule. The results are summarized in Figures 6 and 7. The data in Figure 6 were collected with the colored end of the capsule up in the reflector cone, whereas the data in Figure 7 were collected with the colored end of the capsule down. In general, the distances in SDs measured from the training-set spectra to those of the adulterated capsules are greater when the colored ends of the capsule are up in the reflector cone. The Euclidean distances, however, are about the same for both capsule orientations. The distance in SDs varies because the BEAST scales the Euclidean distance with the probability of the point lying in its particular direction, and the training-set cluster size (probability) is larger when capsules are measured with their white ends pointing up in the reflector cone. Figure 8 shows one of six orthogonal views of the four-dimensional wavelength space in which the Datriil capsules were analyzed. The Figure 8 data were obtained with the colored end of the capsule up. The corresponding colored-end-down views are similar; however, the training-set cluster is slightly larger and the distances to the contaminated samples are slightly smaller. The net effect of these changes

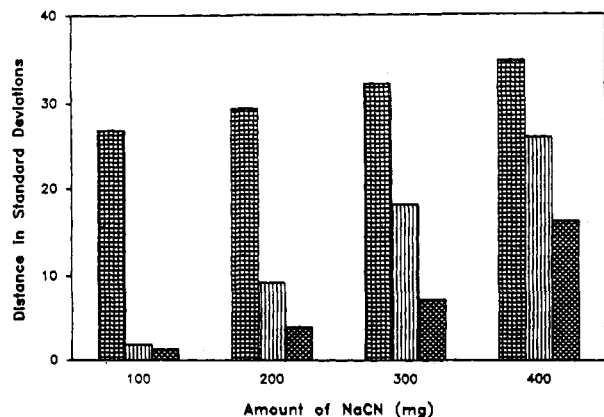

Figure 6. Datriil capsules read with the colored end up in the reflector cone, containing approximately 100, 200, 300, and 400 mg of NaCN packed in three configurations: in the colored end (crosshatch), in the white end (vertical line), and mixed throughout the capsule (diagonal crosshatch). The distance in standard deviations is given in terms of the training set of unadulterated Datriil capsules in the direction of the NaCN-containing capsule.

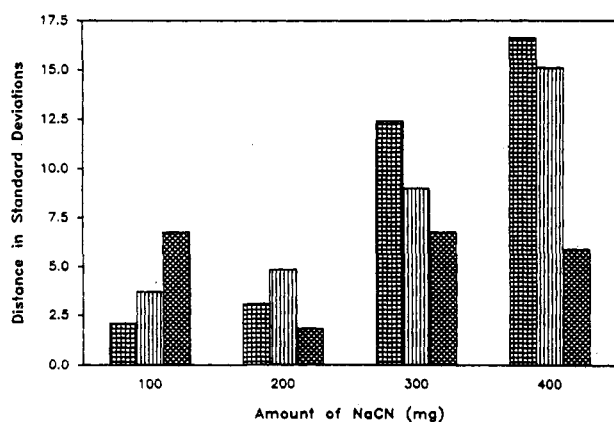

Figure 7. Datriil capsules read with the colored end down in the reflector cone (white end up), containing approximately 100, 200, 300, and 400 mg NaCN packed in three configurations: in the colored end (crosshatch) in the white end (vertical lines), and mixed throughout the capsule (diagonal crosshatch). The distance in standard deviations is given in terms of the training set of unadulterated Datriil capsules in the direction of the NaCN-containing capsule. The seemingly anomalous 100 mg "mixed" reading is probably the result of particle-size noise from, for instance, a large NaCN crystal against the blue end of the capsule wall.

is to reduce the sensitivity of NIRA and the BEAST when measurements are taken through the white end of the capsule (i.e., with the colored end down in the cone). This result is predictable because NIRA gives information about particle size as well as about the chemical contents of a capsule; the particle-size information is obscured somewhat by the light-scattering medium in the white end of the capsule.

Figure 7 demonstrates further the effect of taking the capsule-contents spectrum through two different layers of gelatin. An examination of the data for the 100- and 200-mg samples show that packing these amounts of NaCN in the white end of the capsule produces greater discrimination (in SDs) than packing them in the colored end. However, packing 300 and 400 mg of NaCN into the white end produces a smaller response than packing the same amount in the colored end. The reason that this reversal is observed is simply that the colored end allows more information about the capsule contents to pass through: when 100 and 200 mg of NaCN are in the white end, essentially all of the sample reflectance reaching the detector passes through the white end. However, when 300 and 400 mg of NaCN are packed into the capsule the capsule is more than half full and a significant amount

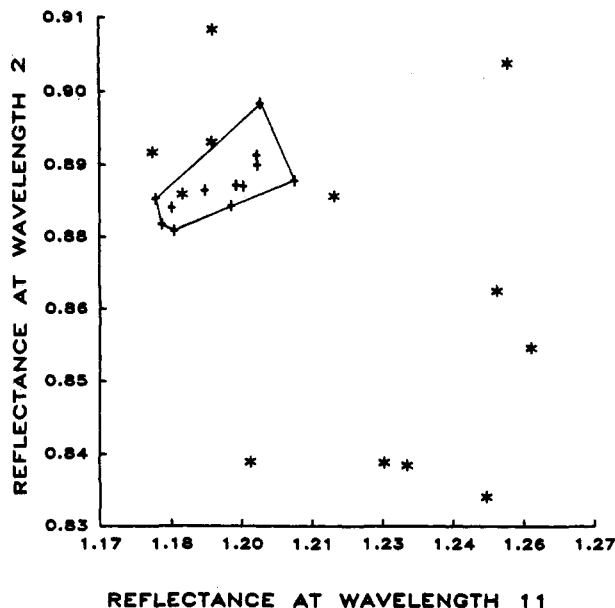

Figure 8. One of six orthogonal views of a four-dimensional space formed by taking Datriil-capsule spectra at four wavelengths for training-set capsules (+) and NaCN-containing capsules (*). This figure shows the smallest convex polygon that can completely surround the training-set spectral points.

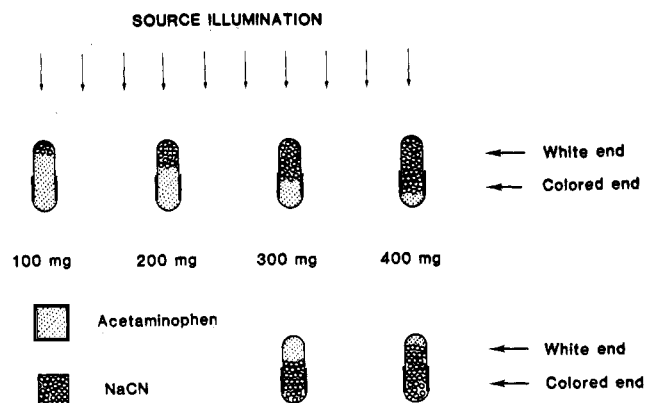

Figure 9. Capsule orientation. The two different kinds of gelatin [scattering (white) and nonscattering (colored)] and the configuration of the contents of the capsule all affect the distance response (discrimination ability) of the BEAST for a given contaminant concentration. These factors can be used to advantage to provide additional information about the sample. The use of a conical reflector (positioned with the base of the cone perpendicular to the source illumination and with the vertex down toward the colored end of the capsules in this figure) permits spatial profiling of the capsule for an identified component.

of the diffuse reflectance is able to reach the detector through the white end as well as the colored end even when the NaCN is packed into the colored end (see Figure 9). Unadulterated capsules are quite full of acetaminophen and typically some must be removed to make room for any added adulterant. The ability to ascertain the profile of the distribution of contaminant in a capsule might provide useful forensic evidence because there is more than one way to introduce an adulterant into a capsule. The distribution profile has obvious applications in quality control as well.

Profiling experiments were also conducted with Anacin-3 capsules by using NaCN as a contaminant. As with the Datriil capsules, approximately 100, 200, 300, and 400 mg of NaCN were placed in the capsule in three configurations (packed toward the colored end, toward the white end, and mixed throughout the capsule). The results appear in Figures 10 and 11. For Anacin-3, the colored end (blue) of the capsule might absorb more in the near-infrared, relative to the white end,

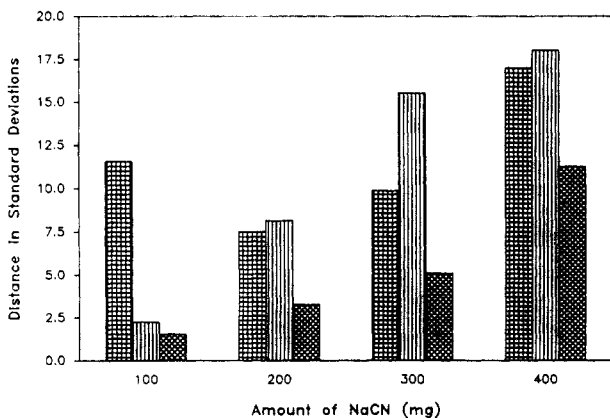

Figure 10. Anacin-3 capsules read with the colored (blue) end up in the reflector cone, containing approximately 100, 200, 300, and 400 mg of NaCN packed in three configurations: in the colored end (crosshatch), in the white end (vertical lines), and mixed throughout the capsule (diagonal crosshatch).

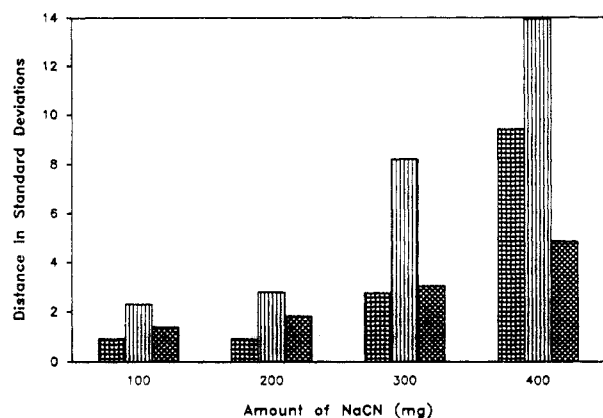

Figure 11. Anacin-3 capsules read with the colored end down in the reflector cone (white end up), containing approximately 100, 200, 300, and 400 mg NaCN packed in three configurations: in the colored end (crosshatch), in the white end (vertical lines), and mixed throughout the capsule (diagonal crosshatch).

than the colored end of a Datriil capsule (green). The ratio of the scale maxima of the figures for Datriil (Figure 6:Figure 7) is 40:17 or 2.29:1, while the same ratio for Anacin-3 is 20:14 or only 1.43:1 (Figure 10:Figure 11). The difference in these ratios indicates that it is more difficult to measure the contents of an Anacin-3 capsule through the colored end than it is to measure the contents of a Datriil capsule through the colored end. Another explanation for the reduced ability of NIRA to read through the colored end of the Anacin-3 capsule is based on the contents of the capsules. In fact, there is a noticeable difference in the consistency of unadulterated powder from a Datriil and an Anacin-3 capsule. Anacin-3 seemed to consist of larger flakes than Datriil and also had a greater tendency to adhere to the walls of the capsule, in spite of attempts to empty it. The amount of powder remaining in the capsules after they were emptied (but just before they were repacked) was not measured, and it is quite possible that this amount was significantly larger in the Anacin-3 capsules than it was in the Datriil product. Special attempts were not made to remove this clinging powder because a tamperer would probably not make such attempts either. "Screening" of the contaminant by the acetaminophen powder could therefore be a significant factor in the Anacin-3 results observed.

Overall, the histograms show that the differences (SD distances) between the contaminated capsules from the training set are smaller for Anacin-3 than they are for Datriil. The immediate reason is that the Anacin-3 spectral train-

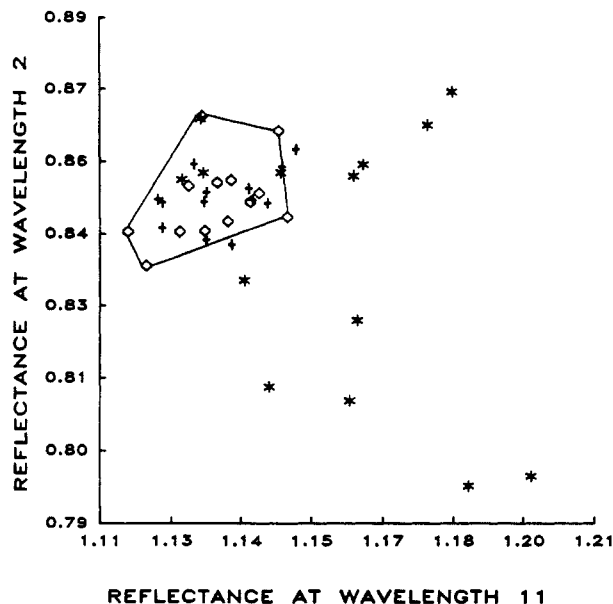

Figure 12. One view of the four-dimensional space in which the Anacin-3 capsules were analyzed. This figure corresponds to the Datriil capsule Figure 8. The smallest convex polygon containing all of the training-set capsules is shown and is larger than the corresponding Datriil polygon. The difference in the size of the polygons is indicative of the greater variability of unadulterated Anacin-3 capsules, a variability that is also reflected in the weight of the Anacin-3 capsules compared to that of the Datriil capsules.

ing-set cluster itself is larger than the Datriil training set, relative to the contaminated samples (compare Figure 12 for Anacin-3 to the corresponding Datriil Figure 8). The fact that the Anacin-3 training-set cluster is larger indicates that Anacin-3 capsules are normally more variable in their contents than Datriils—a fact confirmed by weighing the capsules in each training set. The mean mass of the Datriil capsules was 694 mg, with a standard deviation of 5.5 mg. The mean of the Anacin-3 capsules was 670 mg with a standard deviation of 19.2 mg. Our samples of Anacin-3 capsules are therefore about 3.5 times more variable than the Datriil units, making the detection of any kind of contamination in Anacin-3 a more difficult proposition than the corresponding determination in Datriil. Nevertheless, the fact that the BEAST responds to the absence of components that should be present as well as to the presence of contaminants that should not be in the sample makes the detection of adulteration possible under less-than-ideal conditions. Table II gives BEAST distances in SDs for NaCN-contaminated Datriil and Anacin-3 capsules. Both capsule orientations (colored end up and colored end down) were checked and the larger of the two discrimination values appears in the table. The use of the larger of the two values is the ordinary mode of operation in process-control applications. When the commonly used limit of 3 SDs is applied to the training-set cluster, it is apparent that all of the contaminated Datriil capsules could be detected and rejected. All but two of the contaminated Anacin-3 capsules are also rejected when only four wavelengths are used. The two Anacin-3 capsules that are not rejected represent the lowest NaCN concentrations in the most unfavorable configurations.

The fundamentally nonparametric character of the Quantile BEAST permits information vectors other than near-infrared wavelengths to be used directly in the calculations as though these vectors were near-infrared wavelengths. For example, the retention time of a substance in a liquid chromatography (LC) experiment could be added to the near-infrared wavelength reflectance data from n wavelengths to produce a BEAST analysis in the $(n + 1)$ -dimensional space created by

Table III. Distances of Anacin-3 Validation Samples from the Training-Set Cluster (Distances in SDs for Each Capsule)

4 wavelengths, 4-D space		
1.82	2.38	1.32
1.38	.68	1.10
2.14	1.17	.87
1.66	1.84	1.12
1.46		
4 wavelengths + weights, 5-D space		
2.23	1.02	1.84
2.33	1.11	1.40
2.44	1.74	.77
2.74	2.04	1.97
1.76		

the addition of the retention time. Distributional assumptions of normality are often hard enough to justify when only near-infrared wavelengths are used, and the addition of dissimilar information only makes these assumptions more difficult to justify. The performance of the BEAST, being free of assumptions regarding data distributions, should prove to be even more superior to parametric methods in such applications. The current proliferation of laboratory information management systems makes a wealth of information available to investigators, most of which might be profitably used with the BEAST.

In order for us to demonstrate this flexibility of the BEAST, we added the total masses of the Anacin-3 training-set capsules to the training set. Capsule mass is an important parameter because, in unadulterated capsules, this variable is rather tightly controlled. In addition, the weighing of capsules is one of the few tests that can be performed more rapidly than NIRA. Of course, capsule weight is not in itself a sufficient indicator of tampering. For example, unadulterated Datriil capsules weighed 694 mg (SD = 5.5 mg) whereas the NaCN-contaminated capsules weighed 711 mg (SD = 61.5 mg). Accordingly, a substantial portion of tainted Datriil capsules would pass a test based on weight information alone.

The last group of Anacin-3 distances in Table II represents the same set of capsules that produced the 4-D-space distances, except that the total mass of each capsule was included to create a 5-D space. The BEAST was then retrained by adding the total capsule mass also to each training set sample. The addition of the mass information is enough to allow the BEAST to correctly identify every NaCN-containing capsule as being tainted.

Control, or validation, samples (unadulterated Anacin-3 capsules that were not used in the training set) are also correctly identified in every case (both with and without the weight information) as being untainted (see Table III). Unlike the situation for Hook's Cold Caps capsules discussed earlier, the unadulterated Anacin-3 capsules were intentionally divided randomly into training and validation sets. The only precaution taken in constructing these sets was to make sure that both sets contained approximately equal numbers of capsules with total masses below and above the mean capsule mass. The more random nature of this selection process increases the distance in SDs of the validation capsules from the training set. As in Table II, the higher value of the two possible capsule orientations (colored end up and colored end down) is shown.

KCN is perhaps the most common highly toxic adulterant added to over-the-counter drugs (12, 13). The detection limit for KCN under optimal conditions in over-the-counter capsules is thus of great interest. KCN was packed into the colored end of eight Anacin-3 capsules, over a range of concentrations from 1 to 87% (by weight). A strong functional

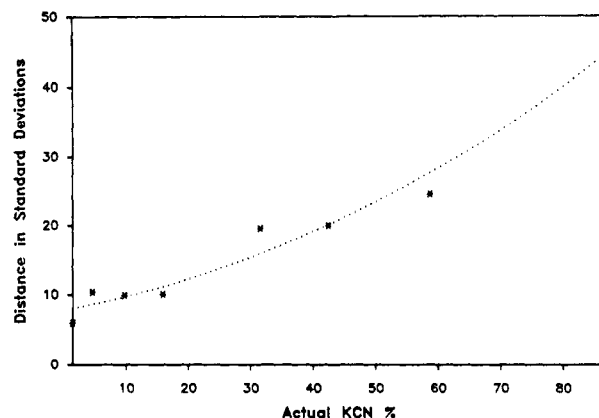

Figure 13. The BEAST distance response (in SDs) as a function of the known KCN concentration in Anacin-3 capsules. These capsules were analyzed with the colored end up in the reflector cone. In general, the distance response is largely quadratic with concentration, as predicted for a conical reflector. The Pearson product-moment correlation coefficient (r) for a quadratic fit to the data is 0.985.

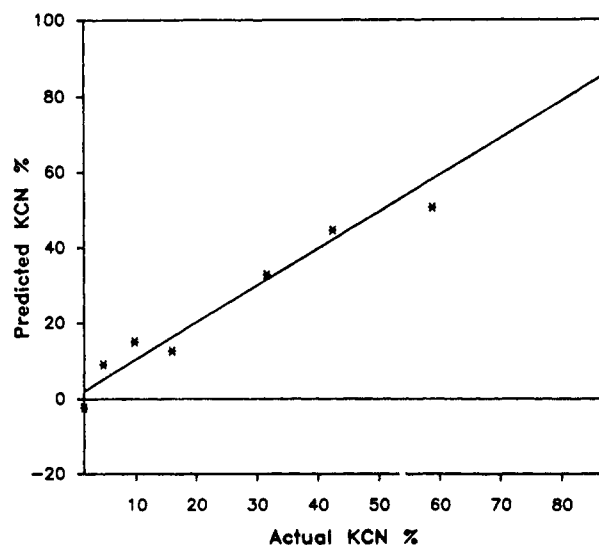

Figure 14. Typical analytical working curve for KCN content in Anacin-3 capsules. The ordinate scale (predicted KCN %) is found from a linear combination of $\log(1/R)$ values at the four wavelengths. The horizontal line shows 0 predicted KCN %.

relationship exists between the concentration of KCN in the capsules and the distance of the capsule (in SDs) from the training set determined by the BEAST (see Figure 13). This relationship suggests that the BEAST might be directly useful as a system or process control technique when (1) the system is defined by one or more monitored variables (such as the wavelengths in this experiment); (2) the BEAST can be trained to recognize a "normal" state as described by typical variations of the monitored variables (in the same way that the BEAST was trained by using a set of unadulterated capsules in the present experiment); (3) a given BEAST distance response in a particular direction can be functionally related back to a parameter of interest in the system (as the quadratic response of the reflector cone can be used to predict the location and amount of a contaminant in a capsule). The ease with which the BEAST problem can be restructured into a form readily solvable by parallel-processing techniques (17) might soon make real-time control with the BEAST an effortlessly attainable goal.

The KCN 3-SD detection limit calculated from the eight Anacin-3 capsules above is 2.6 mg (less than 0.4% of the typical weight of an Anacin-3 capsule). Figure 14 depicts the relationship between the actual KCN concentration and the KCN concentration predicted by NIRA when four wave-

lengths are used for the eight Anacin-3 capsules. The smallest amount of KCN placed in these capsules, 9 mg, caused the capsule in which it was placed to appear 5.96 SDs from the training set in 4-D (4-wavelength) space.

CONCLUSIONS

The Quantile BEAST method, when used in conjunction with NIRA data at only four wavelengths, is able to quickly detect a wide variety of contaminants in capsules, obviating the need to open them. The ability of this technique to detect the absence of components that should be present as well as the presence of components that should be absent enables it even to signal the presence of contaminants that have no near-infrared absorption. Good results are achieved on a simple filter-based instrument, without the need for complex wavelength-selection procedures. The detection limit for KCN in capsules that has been obtained in this work is as much as 2 orders of magnitude below the lowest reported lethal dose (13). Substances other than KCN in capsules could also be detected at low concentrations. Selecting analytical wavelengths near the absorption features of components of interest should improve detection limits beyond those observed in these experiments.

A representative training set composed of unadulterated samples is required to train the BEAST algorithm to recognize a good sample. In this research, collecting the training-set spectra took less than 1 h and training the BEAST algorithm required less than 5 s. All of the training-set spectra were collected in a single day, but the tampering experiments took place over a period of 2 weeks. Nevertheless, repeated runs of validation samples showed that the calibration remained

stable throughout the duration of the experiment. More samples, it seems collected over time, would only enhance the reliability of the method.

Registry No. Fe₂O₃, 1309-37-1; Al, 7429-90-5; NaF, 7681-49-4; As₂O₃, 1327-53-3; NaCN, 143-33-9; KCN, 151-50-8.

LITERATURE CITED

- (1) Tift, S. *Time* 1982, 120(Oct. 11), 18.
- (2) Church, G. J. *Time* 1982, 120(Oct. 18), 16-18.
- (3) Church, G. J. *Time* 1982, 120(Nov. 8), 27.
- (4) Wolnik, K. A.; Fricke, F. L.; Bonnln, E.; Gaston, C. M.; Satzger, R. D. *Anal. Chem.* 1984, 56, 466A-474A.
- (5) Waldhole, M. *Wall Street Journal* 1986, (Feb. 14), 3.
- (6) Davidson, S. *Time* 1986, 127(Feb. 24), 22.
- (7) *Wall Street Journal* 1986, (Jun. 19), 2 and 18.
- (8) Shenon, P. *New York Times* 1986, (Mar. 21), A1 and D19.
- (9) *U.S. News and World Report* 1986, 100(Mar. 31), 8.
- (10) Greenwald, J. *Business Insurance* 1986, Feb. 24, 2.
- (11) Andresky, J. *Forbes* 1986, 137(Apr. 28), 76-77.
- (12) Borman, S. A. *Anal. Chem.* 1982, 54, 1474A.
- (13) Sax, N. I. *Dangerous Properties of Industrial Materials*; Van Nostrand-Reinhold: New York, 1984.
- (14) Reese, K. M. *Chem. Eng. News* 1982, 60(Dec. 13), 82.
- (15) Hadzija, B. W.; Mattock, A. M. *Forensic Sci. Int.* 1983, 23, 143-147.
- (16) Wetzel, D. L. *Anal. Chem.* 1983, 55, 1165A-1176A.
- (17) Lodder, R. A.; Hieftje, G. M. *Anal. Chem.*, submitted for publication.
- (18) Efron, B. *Biometrika* 1981, 68(3), 589-599.
- (19) Honigs, D. E.; Hirschfeld, T. B.; Hieftje, G. M. *Appl. Spectrosc.* 1985, 39, 1062-1065.
- (20) Honigs, D. E.; Hieftje, G. M.; Hirschfeld, T. B. *Appl. Spectrosc.* 1984, 38, 844-847.
- (21) Mark, H. L.; Tunnell, D. *Anal. Chem.* 1985, 57, 1449-1456.
- (22) Mark, H. L. *Anal. Chem.* 1986, 58, 379-384.

RECEIVED for review December 3, 1986. Accepted April 6, 1987. This work has been supported in part by the National Science Foundation through Grant CHE 83-20053, by the Office of Naval Research, and by the Upjohn Company.

Effect of Primary Ion Beam Parameters on the Secondary Ion Emission of Biomolecules from Liquid Matrices

Richard B. Cole,^{1,2} Christian Guenat,¹ J. Ronald Hass,³ and Richard W. Linton*²

Laboratory of Molecular Biophysics, N.I.E.H.S., P.O. Box 12233, Research Triangle Park, North Carolina 27709, Department of Chemistry, University of North Carolina, Chapel Hill, North Carolina 27514, and Triangle Laboratories, Inc., P.O. Box 13485, Research Triangle Park, North Carolina 27709

A liquid metal ion source (Ga⁺) interfaced to a double-focusing mass spectrometer (VG ZAB-2F) was used to investigate the secondary ion mass spectrometry (SIMS) of biomolecules. SIMS studies were performed on three analyte compounds suspended in liquid matrices. Variations in the secondary ion profile of the peptide methionine enkephalin were probed via monitoring of both the protonated molecular ion (*m/z* 574) and fragment ion (*m/z* 120) signals. Temporal fluctuations in signal intensity as a function of primary ion current density (controlled by the primary beam focus) were measured. Variations in the relative signal intensities of the two ions, as a function of local primary ion dose (controlled by the rastering speed), were characterized. The ability to obtain images of both the protonated molecular ion and fragment ions was also demonstrated for methionine enkephalin in a liquid matrix protruding through a microscopic grid.

Liquid metal ion (LMI) emitters are rapidly achieving

¹ N.I.E.H.S.

² University of North Carolina.

³ Triangle Laboratories, Inc.

prominent stature as primary ion sources for secondary ion mass spectrometry (SIMS). Their utility has been demonstrated in the application of spatially resolved inorganic SIMS to metal and semiconductor analysis (1) and to the analysis of alkali and alkaline-earth metals in biological specimens (2). The feasibility of molecular level organic compound analysis using LMI sources has also been demonstrated for a limited number of applications using a low current density primary beam directed at compounds dissolved in a glycerol matrix (3) and for the two-dimensional molecular imaging of a relatively stable organic liquid in an ion microprobe system (4).

A unique feature of the LMI source is the small "virtual" source size, of the order of 10 nm in diameter (5), which enables electrostatic focusing of the primary ion beam to microscopic dimensions. Furthermore, primary beam current densities can be controlled (as will be described) over several orders of magnitude, from the low density conditions used in "static" SIMS experiments (<10⁻⁹ A cm⁻²) (6) to the ultimate focus condition (>10⁻² A cm⁻²) (4) associated with "dynamic" SIMS experiments. This range corresponds to local ion dose rates extending from approximately 10¹⁰ to 10¹⁷ ions cm⁻² s⁻¹.

Success in sputtering fragile organic molecular species using the highest primary ion current densities in this indicated